

HOBART

COMBI Plus 10 level GN 1/1 electric oven

Ref. HPJ101E

COMBI PLUS THE ESSENTIALS

Intelligent cooking®:

CoreControl: power is adjusted to suit the load
AirControl®: speed control and auto fan reverse
JetControl: advanced injection technology
Rapid cooling of the oven cavity

FastPAD:

Touch control panel, intuitive and ergonomic

Integral TwinControl:

Exclusive patented system doubling the essential oven functions

Full Cleaning System:

Cleaning system with automatic chemical supply

Consobox:

Tracks the ovens historic consumption levels



TECHNICAL SPECIFICS

- * FastPAD® toughened glass control panel: comprising a large colour LCD touch screen and coding knob.
- * **Aircontrol®:** Auto reverse ventilation, adjustable from 1 to 100%.
- * **Airdry+ :** Rapid product drying by opening the motorised vent, for a crispier exterior, ventilation provided by 1 fan.
- * **CoreControl:** Automatic adjustment of the oven power to suit the load being cooked, for results that are always to the precise degree required.
- * Continuously available thanks to immediate adjustment to the required temperature.
- * Power down: Automatically switches to energy saving mode after a period of inactivity (adjustable).
- * The oven can be preheated out of hours.
- * Cooking cavity fitted with runners giving a capacity of **10 levels** for GN 1/1 (325 x 530mm) spaced **67mm** apart.
- * **«FullCleaning System»** Automatic cleaning programme: Automatic cleaning with integral chemical pump. 3 possible levels of cleaning.
- * **7 cooking modes:**
 - Convection from 0 to 250°C
 - Saturated steam: steam to 98°C
 - Combined from 30 to 250°C (with humidity adjustable from 0 to 99%)
 - Low temperature: steam from 30 to 97°C
 - High temperature steam: steam from 99 to 105 °C
 - Regeneration
 - Delta T
- * **Automatic cooking mode:**
 - Immediate access to cooking programmes.
 - 80 preloaded recipes as standard with the option to adjust the degree of cooking and the colouration.
 - It is possible to create entirely personalised recipes.
 - Displayed as text or as pictures via the library within the oven.
 - Recipes are classified by family and / or in « my recipes ».
- * **Service mode**
 - Tracking software kit supplied with the oven.
 - Transfer recipes and photographs via a computer.
 - Parameters can be modified to give maximum personalisation.
 - Visual Diagnostic System: interactive screen intended for technicians.
- * **Functions**
 - **Automatic oven cavity cooling**, door closed: improved reactivity.
 - **Humidifier :** provides instant steam (shot of vapour): ideal for bread.
 - **Hold function :** temperature holding phase after cooking (semi static oven). Avoids the surface of the product drying out.
 - **Automatic rinse** possible between cooking operations, replaces the spray hose.
 - **MultiTimer:** cooking times can be programmed for each level : bringing greater flexibility during service
- * **Equipment**
 - Cool touch athermic double glazed clipped door with left or right hand rotation of the handle to open, hinged to the left and a simple push closure. Opens to 180° with hinged internal glass to make cleaning easier.
 - Cavity illumination by a strip of LEDs in the door.
 - Condensation recovery channel under the door and below the oven drains continuously.
 - Features electrical protection, a door safety and thermal overload protection.
- * **Standard supply**
 - 1 set of runners with 10 level max capacity spaced 67mm apart.
 - Rotisserie core probe 4.5mm diameter 100mm long
 - USB port

ACCESSORIES / OPTIONS

- * Stands with storage runners under (see data sheet for stands).
- * Ovenware support module.
- * Banqueting system : plate support module, deposit table with insulated cover support.
- * 20 levels rack kit with "optimum gap" for 10 levels GN1/1 ovens (multilevel stainless runners optimise the available space to suit the depth of containers or the product to be cooked).
- * Core probe for delicate products, probe 1.7mm diameter 100mm long.
- * Energy economiser kit.
- * HACCP record output kit: HACCP outlet comprises 2 x 10m copper cables exiting the rear.
- * Retracting spray hose kit / Independant spray hose kit.
- * Hood (see specific technical data sheet).
- * Grills (3 or 5).
- * Handed oven door (hinge on right).
- * Three phase 230V + Earth option.
- * 60Hz option.

NORMS: Conforms to

EN 60-335-2-42: European norm relating to the safety of electrical appliances.
(French norm: classification index C 73-842).
IP 25 and IK 9: Protection indices. **XP U 60-010:** Hygiene.



HPJ101E

- ELECTRICAL connection**
 Electric inlet at 935mm from the floor.
 Protection required:
 - 400V: 32A MCB (Miniature Circuit Breaker) with B curve and 30mA RCD (Residual Current Device)
 - 230V: 50A MCB (Miniature Circuit Breaker) with B curve and 30mA RCD (Residual Current Device)

- Potable COLD WATER**
 Water inlet at 765mm from the floor.
 A local stop cock is required.

- SOFTENED WATER**
 Water inlet at 765mm from the floor.
 A local stop cock is required.

- DRAIN**
 Drain outlet at 730mm from the floor.
 The water discharged could be condensate and at very high temperature, use material that is suitable for high temperatures.
 There must be a trap between the unit and the mains drainage to prevent odours.

- Vent with choke**

- Exit for surplus steam**

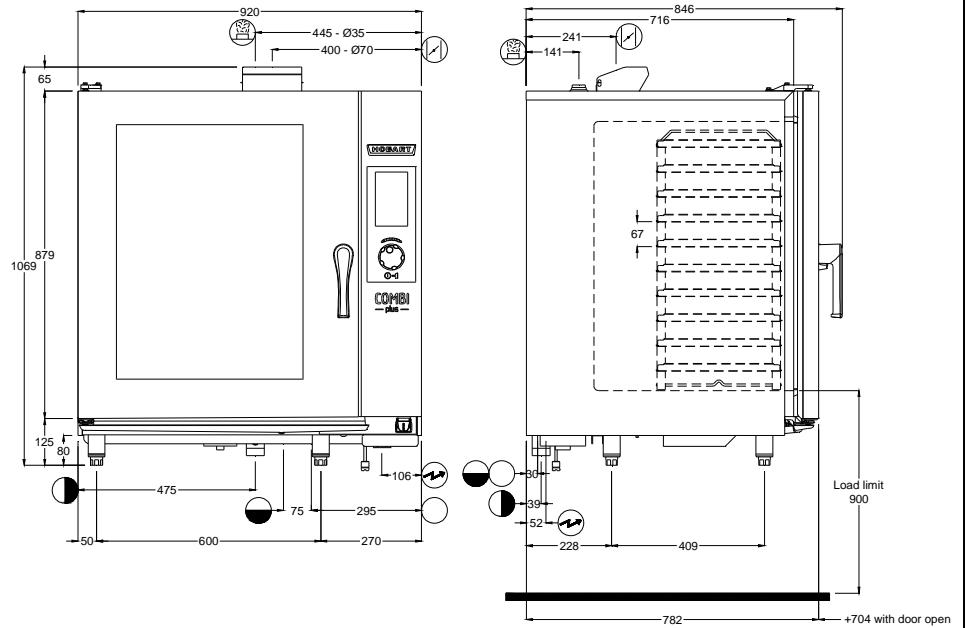

MODEL

HPJ101E

DIMENSIONS (mm)

External	Height 1069; Width 920; Depth 846
Oven height with stand	1768
Cavity	Height 722; Width 630; Depth 535

CAPACITIES

Number of covers per day	240
Usable oven capacity (dm ³)	115
GN 1/1 ovenware (325 x 530)	10
Max. depth of containers (mm)	55
Space between levels (mm)	67
Maximum capacity (kg)	40

PACKAGING (mm)

Height	1200
Width x Depth	1020 x 900

WEIGHT (KG) (gross / net)

145 / 125

CLEARANCES

Left: 4cm / Right: 50cm

TEMPERATURE RANGE

0 to 250°C

CORE TEMPERATURE RANGE

0-99°C

TIMER

99 hours

- ELECTRICITY** (Three phase 230V+E or 400V+N+E)

Voltage	I. Max (A)	Power (kW)
230V 3a.c.	38.8	15.3
400V 3Na.c.	23.0	15.3

- POTABLE COLD Water / SOFTENED Water**

Pressure (Min / Max)	150/600 kPa (1.5 bar / 6 bar)
Cold water max temperature	23°C
Softened water max temperature	23°C
Nature	168 µm filter integral with the oven
Hardness	Softened Max. 7°TH (5°e, 4°h, 70ppm)
Water quality	Chloride Cl ⁻ : 100 mg/l max. / Chlorine Cl ₂ : 0.2mg/l max.
Conductivity	Mini 20 µS/cm
Connection	20/27 threaded (G 3/4)
Instant maximum consumption	5 L/min

- DRAIN**

Condensate temperature	Approx. 98°C
Connection	Vertical exit 40/49 threaded stainless (G 1"1/2)

CONSTRUCTION

Cavity and Cladding	18-10 Stainless
---------------------	-----------------

EQUIPMENT TYPE

Against a wall - Not stackable